

T500

1. Roll-bar estensibile
Extensible roll-bar
2. Sponde estensibili
Extensible side
3. Protezione posteriore cassone
Rear dumper protection
4. Plancia di comando
Console drive
5. Leva ribaltamento idraulico
Hydraulic tipping lever
6. Leva marce
Gear lever
7. Leva velocità
Speed lever
8. Leva ribaltamento manuale
Manual tipping lever



T500

Ribaltamento manuale
Manual tipping



T500H

Ribaltamento idraulico
Hydraulic tipping

T500

MOTORE

Tipo motore

Benzina

Honda GX200

Cilindrata

196cc

Potenza

6,5 HP

Avviamento

Manuale / Elettrico

MACCHINA

Trasmissione

Meccanica

Numero marce

6+2

Sterzata

Con disinnesti meccanici

Freno

Ganasce

Sistema di sicurezza

A leva con rullo

Velocità di avanzamento lenta (1-3)

0,50 - 1,30 Km/h

Velocità di avanzamento veloce (4-6)

1,80 - 4,90 Km/h

Velocità retromarcia (1-2)

0,60 - 2,30 Km/h

Ribaltamento

Manuale

Supporto ribaltamento

Pistone a gas

Portata in piano

500 Kg

Portata su piano Inclinato

350 Kg

Inclinazione max

30%

Peso netto

210 Kg

Peso con imballo

240 Kg

ENGINE

Engine type

Gasoline

Honda GX200

Displacement

196cc

Power

6,5 HP

Starting

Recoil starter / Electric starter

MACHINE

Transmission

Mechanical

Number of gears

6+2

Steering

With mechanical disengagements

Brake

Brake shoes

Safety system

Lever with roller

Slow forward speed (1-3)

0.50 - 1.30 km/h

Fast forward speed (4-6)

1.80 - 4.90 km/h

Reverse speed (1-2)

0.60 - 2.30 km/h

Tipping

Manual

Tipping support

Gas piston

Load capacity on flat surfaces

500 kg

Load capacity on inclined surfaces

350 kg

Maximum inclination

30%

Net weight

210 kg

Weight with packaging

240 kg

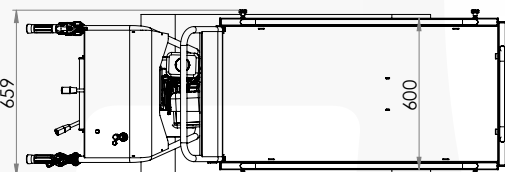
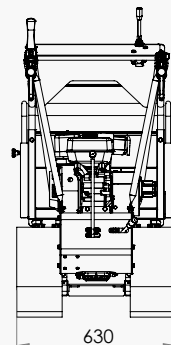
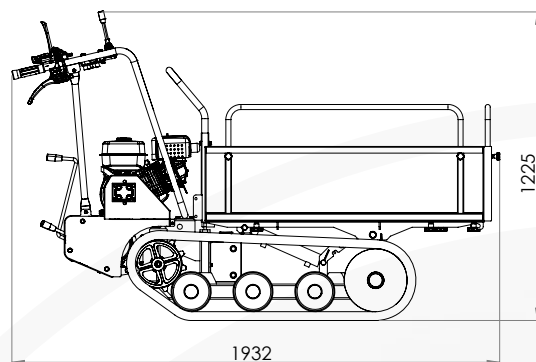



T500

T500H



T500HD