

# H780HT

1. Pala autocaricante  
Self loader
2. Dumper 0,32m<sup>3</sup>  
Dumper 0,32m<sup>3</sup>
3. Protezione superiore dumper  
Dumper upper protection
4. Plancia di comando  
Console drive
5. Pedana operatore, pieghevole  
Operator platform, foldable
6. Sistema rulli basculanti  
Roller balanced system



## MOTORE

<b>Tipo motore</b>	<b>Tipo motore</b>
<b>Benzina</b>	<b>Diesel</b>
Honda GX390	Yanmar L100
<b>Cilindrata</b>	<b>Cilindrata</b>
389 cc	420 cc
<b>Potenza</b>	<b>Potenza</b>
13 HP	11 HP

**Avviamento**  
Elettrico

## MACCHINA

**Trasmissione**  
Idrostatica

**Tipo motore Idraulico**  
Orbitale

**Cilindrata motore Idraulico**  
200 cc

**Tipo pompa ad Ingranaggi**  
Tripla ad ingranaggi

**Cilindrata pompa**  
Fissa

**Pressione max**  
180 bar

**Pressione di lavoro**  
150 bar

**Sistema di sicurezza**  
Valvola overcenter / Freno

**Volume serbatoio olio**  
14 L

**Ribaltamento**  
Idraulico

**Dimensioni cingoli**  
180 x 72 x 40

**Velocità**  
2 velocità: 2,5 / 4 km/h

**Portata in piano**  
800 kg

**Portata su piano inclinato**  
600 kg

**Inclinazione max**  
30%

**Peso netto**  
700 kg

**Peso con imballo**  
750 kg

## ENGINE

<b>Engine type</b>	<b>Engine type</b>
<b>Gasoline</b>	<b>Diesel</b>
Honda GX390	Yanmar L100
<b>Displacement</b>	<b>Displacement</b>
389 cc	420 cc
<b>Power</b>	<b>Power</b>
13 HP	11 HP

**Starting**  
Electric starter

## MACHINE

**Transmission**  
Hydrostatic

**Hydraulic motor type**  
Orbital

**Hydraulic motor displacement**  
200 cc

**Gear pump type**  
3 Stage gear pump

**Pump displacement**  
Fixed

**Max pressure**  
180 bar

**Working pressure**  
150 bar

**Safety system**  
Overcenter valve / Brake

**Oil tank volume**  
14 L

**Tipping**  
Hydraulic

**Rubber track size**  
180 x 72 x 40

**Speed**  
2 speed: 2,5 / 4 km/h

**Payload in flat ground**  
800 kg

**Payload in climbing ground**  
600 kg

**Max gradeability**  
30%

**Net weight**  
700 kg

**Gross weight with packaging**  
750 kg

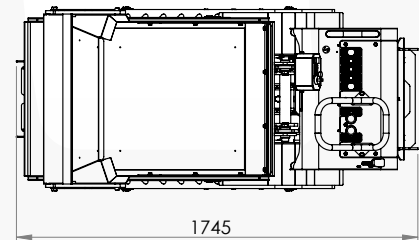
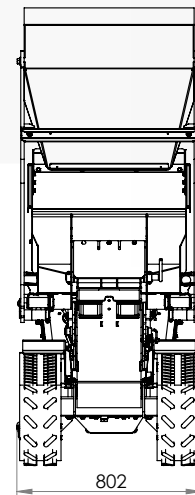
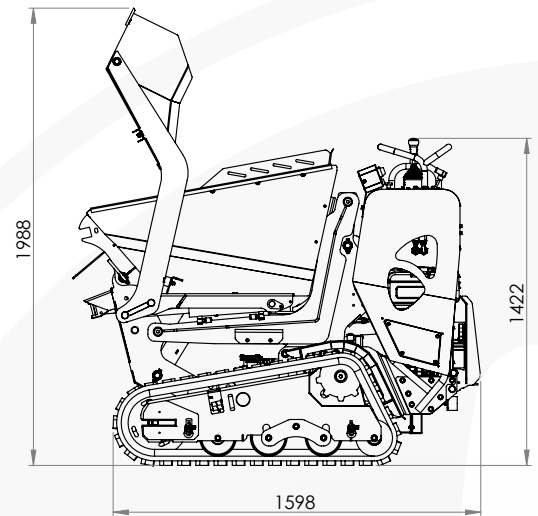



## **H780HT**

*senza  
pala autocaricante  
without self loader*



## **H780HT**

*con  
pala autocaricante  
with self loader*

*console drive  
plancia comandi*



**H780HT**  
*concrete mixer*

**H780HT**

**FORK LIFT**



**H780HT**

**SNOW BLADE**

