

H600

1. Pala autocaricante
Self loader
2. Dumper 0,22m³
Dumper 0,22m³
3. Protezione superiore dumper
Dumper upper protection
4. Plancia di comando
Consolle drive
5. Pedana operatore, pieghevole
Operator platform, foldable
6. Protezione rulli
Roller protection



H600

MOTORE

Tipo motore Benzina Honda GX270	Tipo motore Diesel Yanmar L70
Cilindrata 270cc	Cilindrata 320cc
Potenza 9.0 HP	Potenza 7.0 HP

Avviamento

Manuale / Elettrico

MACCHINA

Trasmissione Idrostatica
Tipo motore Idrraulico Orbitale
Cilindrata motore Idrraulico 200cc
Tipo pompa ad Ingranaggi Gruppo 2 singola divisore flusso a 3 vie
Cilindrata pompa Fissa
Pressione max 180 BAR
Pressione di lavoro 150 BAR
Portata pompa 10,5 cc/RPM
Sistema di sicurezza Valvola overcenter
Volume serbatoio olio 14 Lt
Ribaltamento Idraulico
Dimensioni cingoli 180X60X38
Velocità 2 velocità : 2/3,6 Km/h
Portata in piano 600 Kg
Portata su piano Inclinato 400 Kg
Inclinazione max 30%
Peso netto 430 Kg
Peso con imballo 485 Kg

ENGINE

Engine type Gasoline Honda GX270	Engine type Diesel Yanmar L70
Displacement 270cc	Displacement 320cc
Power 9,0 HP	Power 7.0 HP

Starting

Recoil starter / Electric starter

MACHINE

Trasmission Hydrostatic
Hydraulic motor type Orbitale
Hydraulic motor displacement 200cc
Gear pump type Group 2 single with divisore at 3 way
Pump displacement Fixed
Max pressure 180 BAR
Working pressure 150 BAR
Pump flow 10,5 cc/RPM
Safety system Overcenter valve
Oil tank volume 14 Lt
Tiping Hydraulic
Rubber track size 180X60X38
Speed 2 speed : 2/3,6 Km/h
Payload in flat ground 600 Kg
Payload in climbing ground 400 Kg
Max gradeability 30%
Net weight 430 Kg
Gross weight with packaging 485 Kg

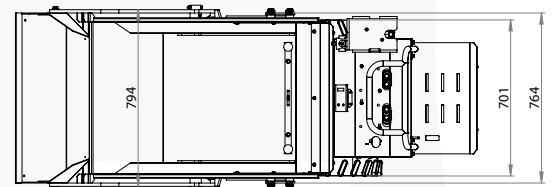
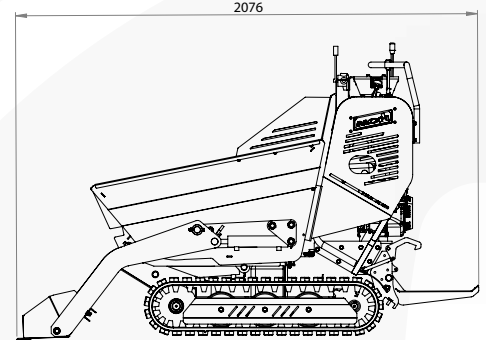
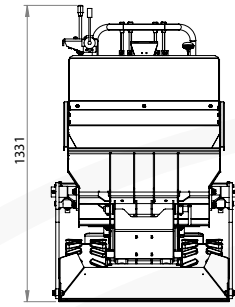



H600



H600C



H600CM
CONCRETE MIXER

H600C
FORK LIFT



H600C
SNOW BLADE

